

Contents

Authorisation for Issue
Amendment Record
Amendment Summary
Distribution List
Preface
List of Abbreviations

Paragraph		Page
1	Introduction	1
2	North Sea Lifting Rules	2
	2.1 Rules	2
	2.2 Notes	3
3	Roles and Responsibilities	5
	3.1 LOLER Representative	5
	3.2 Vessel Crew	5
	3.3 Deck Foreman	5
	3.4 Banksman	5
	3.5 Slinger	6
	3.6 Crane Operator	6
4	Competence Requirements and Standards	7
	4.1 Deck Foreman	7
	4.2 Banksman	7
	4.3 Slinger	7
	4.4 Crane Operator	8
	4.5 Training	8

Contents (cont'd)

5	General Crane Operations	9
	5.1 Control of Lifting Operations – Communications	9
	5.2 Deck-to-deck Lifting	11
	5.3 Cargo Handling – Supply Vessels	13
	5.4 Crane Operation – FPSOs and DSVs	14
	5.5 Bulk Hose Handling	14
	5.6 Personnel Carrier Transfers	15
	5.7 Helicopter Operations	15
6	Adverse Weather Conditions	16
	6.1 Electrical Storms	16
7	Security of Cargo	18
	7.1 Cargo Carrying Units or Baskets	18
 Figure		
1	BS 7121 Hand Signals	10
2	Adverse Weather Matrix	17
Addendum 1	References	
Addendum 2	Cargo Handling and Toolbox Talk Record Form	
Addendum 3	General Instructions for Crane Operators	
Addendum 4	Use of Lifting Accessories	
Addendum 5	Eyebolts	
Addendum 6	Estimation of Weight	
Addendum 7	Safe Working Loads and Breaking Loads	

Authorisation for Issue

Technical Authority

Name: Peter J Faulkner

Signature: _____

Date: _____

Position: TAR and Construction Manager
Bruce/Keith/Rhum

Amendment Summary

Issue No	Date	Description
Issue 1 document control action	August 2003 August 2004	First issue. Distribution List updated.

Distribution List

Holders of Controlled Hard Copy

Copy	Copyholder	Location
01	Data Control Centre (DCC)	ODL, Aberdeen

Virtual Copyholders

Copy	Copyholder
01	Document Technical Authority
02	G ABZ SMS Notifications

Preface

Review and Update

This document will be subject to 12-monthly review and update, when document holders will have the opportunity to express opinions and suggest improvements.

However, the document control system allows for continuous update of this document. As such, any user may at any time identify an error or suggest an improvement using an Amendment Proposal proforma which is available electronically on the UKCS SMS website, from the Data Control Centre (DCC) Supervisor or from the Technical Authority.

All holders of this document are registered so that they can be sent updates and be kept informed of changes or reviews.

Responsibility of Copyholders

It is the responsibility of the registered copyholder of controlled hard copy versions to maintain the accuracy of the document by ensuring that all updates are promptly incorporated and acknowledged.

Furthermore, the registered copyholder of controlled hard copy versions must at all times maintain custody of this document unless prior approval is given by the relevant Technical Authority.

The roles and responsibilities of copyholders and 'virtual' copyholders are detailed in Section 1 of the Document Control Procedure (UKCS-DCM-001).

List of Abbreviations

ACoP	Approved Code of Practice
ASCo	Aberdeen Service Company
CCU	Cargo Carrying Units
CITB	Construction Industry Training Board
COSHH	Control of Substances Hazardous to Health
DSV	Diving Support Vessel
FPSO	Floating Production, Storage and Offloading
HLO	Helicopter Landing Officer
IWRC	Independent Wire Rope Core
LOLER	Lifting Operations and Lifting Equipment Regulations
MHC	Manual Handling Contractor
MODU	Mobile Offshore Drilling Unit
OIM	Offshore Installation Manager
OPITO	Offshore Petroleum Industry Training Organisation
RCI	Rated Capacity Indicator
SLI	Safe Load Indicators
SQA	Scottish Qualifications Authority
SVQ	Scottish Vocational Qualification
SWL	Safe Working Load
UKOOA	United Kingdom Offshore Operators Association
VHF	Very High Frequency

1 Introduction

The purpose of this document is to provide deck crews and crane operators with:

- Guidance on the minimum standards required for deck operations offshore
- Examples of good practice
- Sources of help and further advice

These procedures shall be used in conjunction with:

- Other BP SMS documents eg:
 - UKCS-TI-010 Practical Guide to LOLER
 - UKCS-TI-011 Crane and Wire Rope Replacement Policy for Offshore Pedestal Cranes on BP Installations
 - UKCS-TI-012 Guidance on Lifting Equipment Supply, Control and Operations
 - UKCS-TI-013 Colour Coding Procedure for Portable, Fixed and Circulating Lifting Equipment
 - UKCS-TI-014 Guidance on the Categorisation/Planning/Risk Assessment and Implementation of Lifting Operations
 - UKCS-TI-015 Pedestal Crane Slew Bearing Maintenance Strategy
 - UKCS-TI-016 Offshore Pedestal Crane Inspection and Maintenance Strategy
 - UKCS-SOP-035 Crane Transfer of Personnel in an Emergency
- Installation's safe operating procedures
- Installation and contractor standing instructions
- BS 7121 Code of Practice for Safe Use of Cranes (Offshore)
- UKOOA Guidelines for the Safe Packing and Handling of Cargo to and from Offshore Locations
- Sparrows Offshore Crane Operator and Banksman/Slinger Integrated Safe Operating Procedure

Following this safe operating procedure shall ensure compliance with the North Sea Lifting Rules that were developed in response to lifting fatalities in the North Sea.

Note: Throughout this document, the use of the word 'should' denotes good practice whereas the word 'shall' means compliance with this document, and is mandatory unless a formal dispensation is obtained for non-compliance.

2 North Sea Lifting Rules

Crane operations can be dangerous and as such, require skilled and competent persons to operate and maintain them. Refer to Paragraph 4 on competence.

Risk assessments for crane operations are contained within the assessment manual held on each Installation, where they have resident personnel assigned. These risk assessments must be reviewed prior to commencement of crane operations. Where appropriate, when an additional risk assessment is necessary, this must be undertaken, documented and retained on record.

When the Slinger/Banksman and other crew members are involved in crane maintenance duties such as rope changes, the applicable risk assessments and Control of Substances Hazardous to Health (COSHH) assessments must be utilised for the activity. During such activities the Manual Handling Contractor's (MHC) procedures must be followed.

Prior to the commencement of lifting operations, all personnel involved in the operation must be involved in a toolbox talk and appraised of the lifting requirements. The allocation of duties, communication of lifting plan content, and risk assessment hazards and control measures shall normally be undertaken by the Deck Foreman, deck crew team leader or person responsible for lifting operations. Refer to Addendum 2.

2.1 Rules

The following fundamental rules will be applied to all lifting operations with zero tolerance. These are taken from the BP North Sea Lifting Rules:

- “(1) All personnel must keep out of any area where they might be injured by a falling or shifting load. Do not stand below loads. Never stand between loads and walls/bulkheads etc. Always ensure an escape route is available.*
- (2) Immediately a lift deviates from the plan or any complication arises, the lifting operation must be stopped and made safe. All personnel should remain in positions clear of the lift until reassessment/replanning of the lift is carried out.*
- (3) Lifting operations will be undertaken by a minimum of three competent people: the Crane Operator, Banksman/Flagman and load handler.*
- (4) The Banksman/Flagman controls the initial lifting of the load, laydown of the load and lifts that are out of the line of vision of the Crane Operator. The Crane Operator is responsible while the load is in the air. The Banksman must:*
 - (a) Ensure that he/she is easily identifiable from other personnel by wearing a hi-vis jacket or waistcoat, which is clearly marked to indicate that they are the authorised Banksman.*
 - (b) Not touch the load. He/she must stand back from the load being handled in a prominent position where they have a good view of the lifting activities.*
 - (c) Remain in communication with the load handler and Crane Operator at all times.*
 - (d) Keep the load handler in sight during the lifting operation.*

- (5) The load handler must:
- (a) Stand clear while a load is lifted clear of the deck and landed, while slack is taken up with or without a load on the hook and must confirm to the Banksman that he is clear.
 - (b) Not touch a load being landed until it is below his/her waist height and never attempt to manually stop a swinging load.
 - (c) Be easily identifiable, and distinct from the Banksman.
- (6) For BP operated Installations and onshore sites, there will be no stacking of containers, baskets, tanks and half-heights.
- For designated Installations where this is not practicable, stacking requires prior permission of the relevant Business Unit Leader and that:
- (a) Equipment is specifically designed for that purpose, and clearly marked as suitable for stacking.
 - (b) Stacking is confined to pre-designated areas.
 - (c) Risk assessment of stacking operations is performed and documented, showing that the risk involved in stacking and de-stacking is as low as reasonably practicable and less than the risk involved in alternative practicable approaches.
 - (d) Stacked containers must have an additional pennant so that the crane hook can be attached/detached while the load handler is standing at deck level.
 - (e) Stacking and de-stacking is controlled by permit."

2.2 Notes

The attached notes are an integral part of the rules listed above:

- "(1) These rules were developed for deck lifts or deck/boat lifts using pedestal cranes on offshore Installations. They will also be applicable to similar lifts using mobile cranes, crawler cranes etc on BP operated onshore sites.

For lifts with other devices (eg workshop cranes, winches, hi-abs), Rules 1 and 2 will always be applicable. Consider the application of Rules 3 to 6 during job planning and risk assessment.

The rules do not specifically apply to the holding in position of items of equipment during well servicing/wireline activities. These specialist activities should be covered by job-specific procedures, permit and detailed risk assessment.

- (2) Rule 1: This includes not getting under slung loads, not getting into areas where they could be trapped between the load and something else. Third parties not involved in the lifting operation also have a responsibility to keep out of areas where lifting is being conducted. This rule is now added to the GBC Golden Rules website and will be incorporated into the Golden Rule booklets at the next revision.
- (3) The load handler may also be designated as Slinger, Deck Operator or Hookman.

- (4) *Rule (5)(b): In some essential laydown areas it is necessary to manoeuvre containers into limited landing areas adjacent to handrails, where the handrails are slightly in excess of waist height. Where it is considered essential to continue using these laydown areas, and the lowest practicable risk is provided by touching the load above waist height to orient it, Installations must identify and document steps to be taken to mitigate the risk to the load handler.*
- (5) *Stacking*
- (a) *It is intended to eliminate stacking of containers and other loads as identified in Rule 6.*
- (b) *For some Installations (particularly some Mobile Offshore Drilling Units (MODUs)) this may not be practicable due to limitations on deck space. The exception to the no stacking rule is intended to cater for these Installations and not to provide a general opportunity for all Installations to stack as soon as deck space becomes congested.*
- (c) *Business Units must designate on which Installations this is not practicable and where stacking may be undertaken. They must also document why the decision to allow stacking was made.*
- (d) *For those Installations where no stacking is not currently practicable, a review should be undertaken to consider what would be required to be able to operate on a no-stacking basis.*
- (e) *However, after appropriate review and documentation, the OIMs may designate particular equipment (eg sphere racks in SNS) as suitable for stacking.*
- (f) *Assets should reassess the design of equipment currently designated as suitable for stacking to confirm that it is fit for purpose, both loaded and empty.*
- (g) *Installations that intend to designate equipment or areas suitable for stacking should consider using the Management of Change process to review and document the justification.*
- (6) *These rules are not exhaustive. They reinforce behavioural aspects of lifting. Procedural and equipment issues such as risk assessment, lifting equipment specification, lifting plans, regulations (eg Lifting Operations and Lifting Equipment Regulations (LOLER) in the UK) are also essential to safe lifting. Crane drivers, load handlers and deck operators should comply with contractors' procedures, Installation procedures and regulatory requirements. They should use risk assessments and toolbox talks where appropriate and must be prepared to stop the job at any stage if the safety of the operation may be compromised.*
- (7) *The Deck Operations and Lifting Forum is currently working with crane and deck operations contractors to identify best practice and establish common procedures for all contractors. New UK standard operating procedures will be developed from this review. This forum will be expanded to include Norway and the Netherlands.*
- (8) *These rules are immediately applicable. Although issued under the overall authority of the Regional Leadership Team, for document control purposes they will be maintained as separate controlled documents within the management systems in UK, Norway and the Netherlands."*

3 Roles and Responsibilities

3.1 LOLER Representative

The LOLER Representative will be governed by the guidance set out in the Practical Guide to LOLER (UKCS-TI-010).

3.2 Vessel Crew

The vessel crew must follow the guidelines for supply vessel operation as detailed in the Marine Operations Manual (UKCS-MAL-001).

3.3 Deck Foreman

The Deck Foreman is responsible for ensuring that:

- Sufficient resources are available
- The competence and skill mix of a team is correct
- Sufficient supervision of persons under training or gaining experience is given to demonstrate competence

3.4 Banksman

The Banksman/Flagman controls the initial lifting of the load, laydown of the load and lifts that are out of the line of vision of the Crane Operator. The Crane Operator is responsible while the load is in the air. The Banksman must ensure that he/she:

- Is easily identifiable from other personnel by wearing a hi-vis jacket or waistcoat, which is clearly marked to indicate that he/she is the authorised crane Banksman
- Does not touch the load. They must stand back from the load being handled in a prominent position where they have a good view of the lifting activities
- Remains in communication with the load handler and Crane Operator at all times
- Keeps the load handler in sight during the lifting operation
- Does not direct the crane in a load path over 'live' plant unless covered by a specific risk assessment
- Removes barrels, drums etc from transit carriers or containers. This shall be carried out using lifting equipment specifically designed for that purpose. Always ensure the integrity of the barrel rim. This equipment shall not be used when lifting barrels or drums across Installation areas. Secure methods of slinging shall be used for this task

3.5 Slinger

The Slinger must:

- Stand clear while a load is lifted clear of the deck and landed, while slack is taken up with or without a load on the hook, and must confirm to the Banksman that he is clear
- Not touch a load being landed until it is below his/her waist height and never attempt to manually stop a swinging load
- Be easily identifiable and distinct from the Banksman

3.6 Crane Operator

Operates the crane under the direction of the Banksman.

They provide:

- Technical advice on the safe operation of the crane
- Judgement on the conditions for safe lifting operations from vessels
- Daily maintenance and checks on cranes

When a situation arises or a condition exists where, in the incumbent's qualified opinion, the safety of personnel, plant or equipment may be jeopardised, they will be expected/required to suspend lifting operations until such time as control measures have been introduced to minimise or eliminate the potential risks.

When lifting operations have been temporarily suspended due to inclement weather or, in the case of a supply vessel, backloading/discharging has stopped, they shall not recommence until the Crane Operator is satisfied that conditions have improved to within the safe operating parameters recommended by the crane manufacturer or imposed by the owner or employer.

4 Competence Requirements and Standards

4.1 Deck Foreman

The Deck Foreman must have the following:

- Supervisory skills including safety leadership, man management and planning
- Knowledge of relevant procedures and policies for deck operations
- Approved training course, either Cogent or Construction Industry Training Board (CITB)
- Experience of lifting operations offshore for not less than 6 months in the previous 2 years
- Formal assessment of competence against the Cogent/CITB standard every 2 years as per UKOOA lifting and mechanical handling guidelines
- Be competent to act as a Banksman/Slinger on the Installation after familiarisation
- Trained and qualified for VHF communication with vessels

4.2 Banksman

Before acting as a Banksman on a specific Installation the Banksman must have all of the following:

- An approved training course certificate from either Cogent or CITB
- Experience of lifting operations offshore for not less than 6 months in the previous 2 years
- Formal assessment of competence against the Cogent/CITB standard every 2 years as per the United Kingdom Offshore Operators Association (UKOOA) lifting and mechanical handling guidelines
- A formal appointment based on the recommendation of the Deck Foreman and Crane Operator after familiarisation with the Installation
- Training and qualification for VHF communication with vessels

4.3 Slinger

The Slinger must have:

- An approved training course certificate from either Cogent or CITB
- Experience of lifting operations offshore for not less than 6 months in the previous 2 years
- Worked under the supervision of competent Slings/Banksmen to gain experience

4.4 Crane Operator

The Crane Operator must be:

- Trained and deemed as competent by a technically qualified assessor to:
 - Offshore Stage 2 for deck operations
 - Offshore Stage 3 for boat operations
- Assessed every 2 years by a qualified assessor in line with BS 7121 Part 11 recommendations
- Achieved or be working towards achieving an Offshore Petroleum Industry Training Organisation (OPITO) Scottish Vocational Qualification (SVQ) Level 2 Offshore Crane Operations qualification or equivalent
- Trained for VHF communication with vessels

Note: These conditions/expectations do not apply to personnel who are engaged on a Crane Operator training programme. Their crane operational activity will be strictly aligned to their levels of formal training and experience.

4.5 Training

4.5.1 Industry Standards

- Cogent Standard of Competence for Offshore Crane Operators Level 2
- Cogent Standard of Competence for Performing Deck Operators Level 2
- Royal Yachting Association approved VHF communication with vessels

4.5.2 Recognised Standards

- Training Guidance Note No 5 (Selection and Training of Offshore Crane Drivers)
- Sparrows/Scottish Qualifications Authority (SQA) Customised Award in Offshore Crane Operations

5 General Crane Operations

5.1 Control of Lifting Operations – Communications

Lack of effective communication is one of the main contributors to safety problems arising from routine and non-routine activities within the industry. Lifting operations may be controlled by hand signals or radio, or both.

The Crane Operator must only respond to hand or radio signals when given by an authorised Banksman. The Crane Operator shall only respond to signals from other persons in an emergency situation, ie when the 'stop' signal is given.

5.1.1 Hand Signals

It is imperative that Crane Operators and Banksmen are familiar with the system of signalling used onboard the Installation. Banksman signals to BS 7121 will be used on BP Installations on the United Kingdom Continental Shelf (refer to Figure 1).

When hand signals are being used, maintain visual contact with the Banksman. Lifting operations must cease if visual contact is lost. These operations can only recommence when a clear line of vision is re-established.

The Crane Operator must ensure that the Banksman signalling system is clearly displayed at a strategic point within the crane operating cabin.

When the Crane Operator's ability to see hand signals from the Banksman is impaired by inclement weather conditions or darkness etc, crane operations are to cease if the Crane Operator feels that the operation cannot be executed safely.

When 'blind' lifts are being conducted by a hand signalling method and more than one Banksman is being used to relay instructions to the Crane Operator, each Banksman shall stand in a position where he/she can be clearly seen by the next person in the chain. All signals shall be clear and precise. The Banksman at the load shall have a complete overview of the activity.

Mobile Crane Signals as Recommended in BS 7121

The signaller should stand in a secure position where HE CAN SEE THE LOAD AND BE SEEN CLEARLY by the driver. Always face the driver if possible and make each signal distinct and clear.

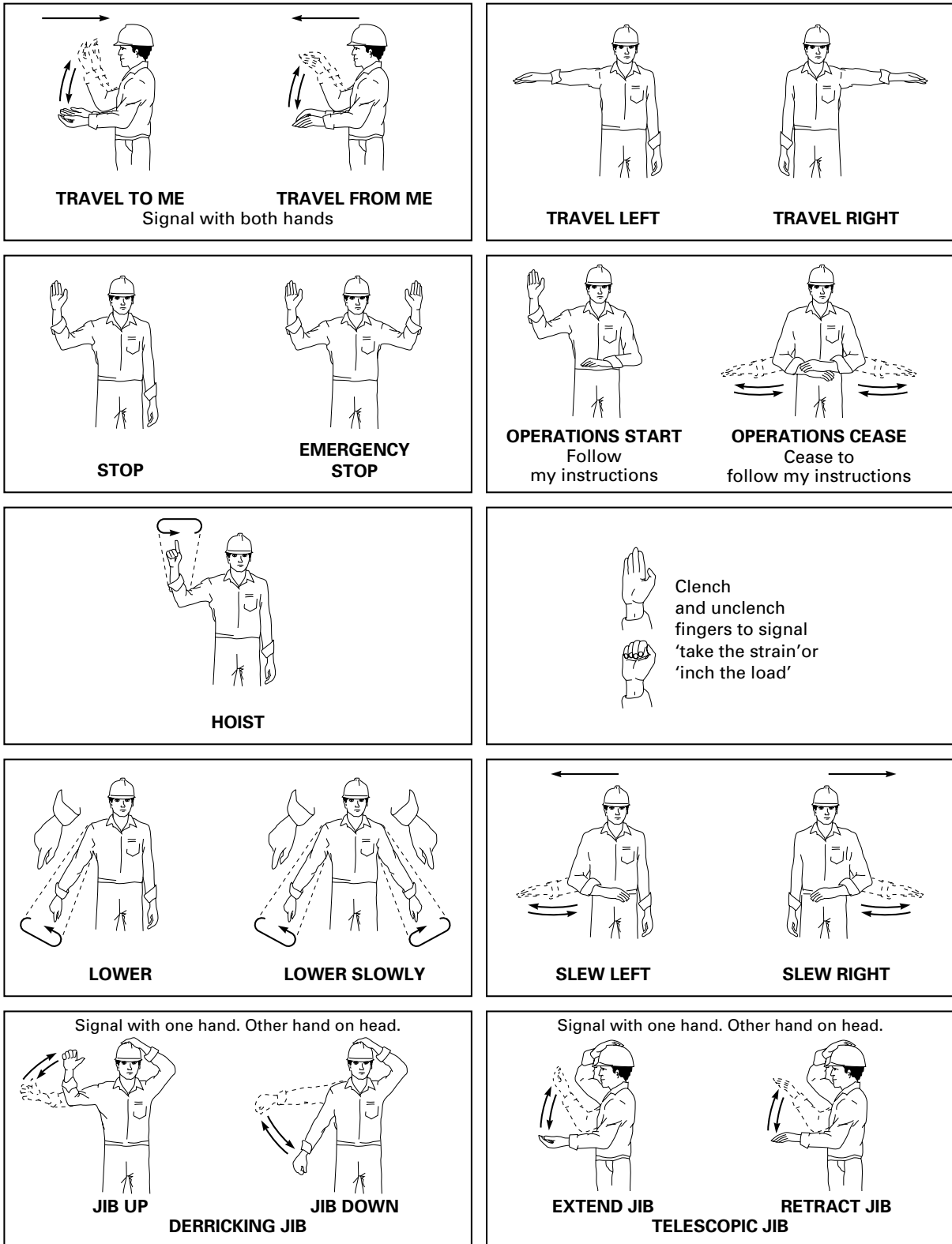

UKCSOP043_024.ai

Figure 1 BS 7121 Hand Signals

5.1.2 Radio Communication

All radio banking operations must be on a dedicated channel, which cannot be interfered with by other users. The radio communication must be confirmed before starting lifting operations.

When radio communication is being used, the Crane Operator is to reach a clear understanding with the Banksman before lifting operations begin. If there is any interruption to the communication, the Crane Operator must stop the lifting operation immediately until communication with the Banksman is re-established.

Radio communication with a vessel must be in a common language. Direct radio communication must be available between the Crane Operator, Banksman, platform deck crew, bridge and vessel deck crew for emergency situation.

Where a vessel is concurrently loading/discharging bulk materials by hose and handling cargo by crane, separate channels will be used for lifting and bulk transfer operations to prevent interference with the control of crane operations.

All VHF users must be licensed.

All personnel involved in lifting operations will be trained in the use of the Installation's radios and radio protocols, including the channels they are allowed to use.

5.2 Deck-to-deck Lifting

5.2.1 Preparation

Before commencing a deck-to-deck lift:

- Define the scope of work, categorise lift risk assessment and confirm that the lift is within the generic lifting plan
- Select team, nominate roles and hold toolbox talk (refer to Addendum 2 Toolbox Talk Record Form for toolbox talk record and pre-lift/backload checklist examples)
- Barrier off area
- Confirm that the radios work

Prior to commencing and during lifting operations, the Banksman and Crane Operator are to take stock of the prevailing weather conditions, eg wind speed/direction and visibility. Lifting operations will not commence if the weather or environmental conditions are liable to jeopardise the safety of the activity.

While there is a shared responsibility for the safety of each lifting operation (eg Crane Operator, Banksman and Slinger), the Banksman controls the initial lifting of the load, laydown of the load and lifts that are outwith the Crane Operator's line of vision. The Crane Operator is responsible while the load is in the air within his line of vision.

Before a load is attached, the Crane Operator must be aware of the weight of the load to be lifted. The Banksman will satisfy himself that the lifting gear being used is certified (eg colour coded), of sufficient capacity and is correctly attached and positioned to prevent uneven lifting or slippage of the load. Check for potential dropped objects and that the load is secure.

If the risk assessment requires taglines the Banksman will ensure that they are attached.

The Banksman will ensure that the hook is over the centre of the lifting point to alleviate any 'drift' in the load as it is lifted clear of the deck.

When lifting from baskets or containers, the lift will not commence until personnel are clear of the immediate area of the lift, ie outwith the vicinity of the basket or container.

5.2.2 Handling and Movement

As the load is lifted off the deck the Crane Operator will monitor the Rated Capacity Indicator (RCI) for a possible overload situation developing.

At the commencement of the first lift, the Crane Operator must check the operation of the hoist brake.

When moving loads across the deck of the Installation, the Crane Operator and Banksman shall be aware of any other activities/obstructions within the crane radius arc and shall avoid the movement of loads over the heads of other personnel.

When carrying out blind lifts, the Crane Operator will monitor the RCI for any loss or increase in the weight of the load. This could indicate that the load has snagged on the superstructure or the adjacent equipment. Cease the lifting operation and advise the Banksman.

The Crane Operator will keep loads within the specified radius of the crane.

Where lifting activities necessitate the crane boom to operate in close proximity to conflicting structures such as drilling derricks, telecom towers, accommodation structures etc, a toolbox talk and lifting plan shall be carried out between all concerned parties, outlining all associated risks and subsequent control measures to be taken.

Where a crane boom is operating in close proximity to conflicting structures, the Crane Operator shall ensure that a Banksman is positioned at a point where he/she has a clear overview of the load, crane boom and potential contact points.

If at any point the Crane Operator becomes concerned that the boom is too close to a conflicting structure, or that they have been instructed by the Banksman to undertake a manoeuvre that may result in a collision, he/she must cease operations immediately and advise the Banksman of his concerns. Crane operations must not recommence until such time that appropriate control measures have been put in place and all necessary precautions have been taken.

When the load remains static for any reason, the Crane Operator must not leave his position at the controls. Where the load is to remain static for prolonged periods, engage the hoist drum brake and the boom drum pawl (where these devices are not automatically applied) that shall prevent the lowering of the suspended load.

5.3 Cargo Handling – Supply Vessels

Prior to startup, ensure that all controls are in neutral position and that the main clutch (where fitted) is disengaged.

Establish radio communication with the Master of the supply vessel or, where applicable, the vessel's deck crew.

Prior to the commencement of supply boat operations, confirm that the prevailing wind and seastate conditions are within operating limits.

The Crane Operator shall ensure that the RCI is adjusted to register the appropriate seastate condition. Any alteration in seastate during cargo handling operations shall be taken into account and the RCI altered accordingly.

The Deck Foreman is to obtain the manifest listing before supply boat operations. Prior to hoisting loads off a supply vessel deck, ensure that the ship's crew has reached a position of safety well clear of the cargo handling area and have given the appropriate signal or instruction to hoist.

Prior to backloading cargo to a supply vessel deck, ensure that the ship's deck crew is in a position of safety, well clear of the intended cargo stowage area.

When hoisting loads off a moving supply vessel deck packed with cargo, the Crane Operator shall be alert for snag-ups or loads that are still lashed to the deck, or for wrongly manifested cargo weights.

During lifting operations, particularly whilst engaged in supply vessel activities, the Crane Operator shall take all necessary actions to avoid excessive impact and avert shock loading being transmitted to the crane. The Crane Operator shall wait for the correct moment to make the lift and shall not be rushed by frantic arm waving from the vessel deck crew personnel.

Where practicable, the Crane Operator shall not use maximum boom radius during supply vessel discharging and backloading operations. The Crane Operator shall assess each individual situation taking into account the supply vessel drift movement and prevailing environmental conditions. Some boom radius shall be retained in reserve to compensate for the drift movement in the event that it is necessary to abort the operation in instances where the supply vessel is unable to hold station alongside the Installation.

If a load is immersed in the sea for any reason, be aware of the possible increase in weight from water absorption. Report the incident to the individual designated by the Offshore Installation Manager (OIM) as the Responsible Person for lifting operations so that he can check the load and/or contents for any damage sustained following its retrieval.

Whenever possible, hoist/lower loads over open water and not over the supply vessel deck.

When discharging long tubulars, baskets or other awkward loads, ensure that taglines are attached to assist with the control and handling of the load on the Installation deck when required by the risk assessment.

The practice of 'cherry picking' cargo or attempting to backload into areas that are not easily accessible is to be strictly avoided.

5.4 Crane Operation – FPSOs and DSVs

The hazards associated with crane operations on Floating Production, Storage and Offloading facilities (FPSOs) and Diving Support Vessels (DSVs) are radically different from fixed Installation, and as such extreme caution shall be taken during crane operations.

Primary considerations shall include:

- Vessel stability (pitch, roll and heave)
- Proximity to live process plant or other equipment
- Establishment of realistic operating parameters
- All individuals involved in the lifting operation shall be familiar with the crane operational characteristics and parameters. They shall also be familiar with the working environment and the combined behavioural pattern of the vessel and crane(s)
- Potential dangers while carrying out lifts outwith the Crane Operator's line of vision, ie blind lifts

5.5 Bulk Hose Handling

Each Installation shall comply with the Marine Operations Manual (UKCS-MAL-001) Section 7, Appendix 7A.

The Crane Operator must exercise extreme caution when transferring bulk/liquid hoses between the Installation and supply vessel. Follow the Banksman's signal and monitor the RCI for any sudden increase in weight that may indicate that the hose has snagged on a protrusion on the Installation or supply vessel.

When engaged in deployment or re-stowage of bulk hoses, the Banksman and handlers must never stand in a position where there is potential for entanglement in a hose or being struck by a falling hose. Other personnel must be kept well clear of the area. The Banksman shall stand in a position where a clear view of the hose handling operation can be attained. (It is strongly advised that safety cages or framework are erected over hose handling stations to protect personnel involved in such operations in the event that a hose becomes detached from the crane or lifting arrangement).

5.6 Personnel Carrier Transfers

Personnel carrier transfers to or from offshore Installations are considered a high-risk operation and shall only be used in exceptional circumstances, ie emergency situation or when transfer is essential and it is not practicable to gain access by less hazardous means. (Refer to Paragraph 4.6 of LOLER Regulation 5 and the Health and Safety Executive Safety Notice 10/80.) Normally the OIM is the only person to permit the use of personnel transfer carriers.

The Dutyholder's policy and local Installation rules on the use of personnel transfer carriers must include:

- Who is responsible for authorising the transfer
- A clear definition of the circumstances for use
- How the procedure is complied with

Where it is necessary to transfer personnel to or from a vessel, the Crane Operator must always have a clear view of the embarkation areas, load path and landing areas.

Check the prevailing weather conditions, eg wind speed and seastate to ensure that they fall within the criteria listed in the Installation's safe operating procedures.

Establish radio communication with the Master of the supply vessel prior to commencement of the transfer operation (refer to Paragraph 5.1.2 on radio communications).

Check that all other criteria required for the operation are met, eg standby vessel has been alerted, passengers are wearing the appropriate immersion suits and lifejackets, and that they have been briefed on all facets of the transfer. Particular reference shall be made to embarkation and disembarkation methods.

Ensure that the Banksman is on hand to take control of signalling in the event that visual contact with the carrier or landing area is lost.

5.7 Helicopter Operations

All crane movements must stop during helicopter operations unless dispensation has been given by the Helicopter Landing Officer (HLO) in consultation with the OIM to carry out special tasks.

If it is not a requirement to place the crane boom on the boom rest during helicopter operations, liaise with the HLO to ensure that the boom is positioned to prevent interference with the flying programme.

The Crane Operator must ensure that, before leaving the crane unattended, the crane boom is placed in the boom rest and/or the slew brake applied. The crane must never be left parked with the boom in the proximity of the helicopter landing deck.

Always ensure that the aviation warning lights remain switched on when the boom is in the air and when A-frames or masts extend to 15m or more above the heli-landing deck.

Where Installation instructions are available detailing the steps to be taken during helicopter operations, then such instructions are to be implemented. The Crane Operator will ensure that they are familiar with the contents of the Installation's standing orders on this subject.

6 Adverse Weather Conditions

At the commencement of each shift, carry out a function check of the boom minimum radius cut-out and the hook block (main/auxiliary) overhoist cut-outs. These checks shall be extended to include maximum radius and maximum payout limits, when they are fitted.

During lifting operations, adverse weather will increase the risks presented to personnel and equipment. To minimise the potential hazards associated with lifting operations, the matrix in Figure 2 provides an example of operational limits for crane hoisting and lifting operations that shall be considered by those involved.

It must be emphasised that this is an example only and the Installation-specific adverse weather policy relative to lifting operations and, where applicable, the crane manufacturer's recommendations must be strictly adhered to at all times.

6.1 Electrical Storms

During electrical storms, lightning can have an adverse effect on the crane's structure, to personnel involved in crane maintenance activities and to general crane hoisting and lifting operations.

Past experiences suggest that where the threat of lightning exists, crane maintenance activities and crane operations must be suspended until such time as the risk of lightning affecting operations has abated.

Assessment of Conditions Offshore					
Mean Wind Speed (knots)	Description	Summarised State of Sea Description	Probable Significant Wave Height (m)	Zone Definition	Additional Information
0 to 1	Calm	Like a mirror.	0	Normal lifting zone	The following situations may require cessation of lifting operations: <ul style="list-style-type: none"> • Loss of radio contact • Loss of visibility • Vessel Master's discretion • Crane Operator's discretion
1 to 4	Light air	Ripples like scales are formed.	0		
5 to 8	Light breeze	Small wavelets, still short but more pronounced; not breaking.	0.1		
9 to 13	Gentle breeze	Large wavelets, crests beginning to break; a few white horses.	0.4		
14 to 21	Moderate breeze	Small waves, growing longer; fairly frequent white horses.	1		
22 to 27	Fresh breeze	Moderate waves, taking more pronounced form, many white horses perhaps some spray.	2		
28 to 35	Strong breeze	Large waves forming, white foam crests more extensive; probably some spray.	3		
36 to 43	Near gale	Sea heaps up, white foam from breaking waves begins to blow in streaks.	4	Review and assessment zone	Lifting only with agreement of: <ul style="list-style-type: none"> • Crane Operator • Supply Vessel Master • Responsible person lifting operations
44 to 52	Gale	Moderately high waves of greater length; edges break in spindrift; foam blown in well-marked streaks.	5.5	No lifting – emergency lifting only (safety of life)	Emergency lifting only. Requires: <ul style="list-style-type: none"> • Risk assessment • Approval by OIM
53 to 61	Strong gale	Moderate high waves of greater length; edges of crests break into spindrift; foam blown in well-marked streaks.	7		
62 to 71	Storm	High waves with tumbling crests; dense streaks of foam; spray might affect visibility.	9		
72 to 82	Violent storm	Exceptionally high waves; sea covered with long white patches of foam, edges of wave crests blown into froth; visibility affected.	11		
83+	Hurricane	Air filled with foam and spray; sea completely white with driving spray; visibility very seriously affected.	14		

Figure 2 Adverse Weather Matrix

7 Securing of Cargo

The vessel's Master is responsible for ensuring that all cargo is properly secured prior to sailing. BP has adopted the [UKOOA Guidelines on the Safe Packing and Handling of Cargo](#) as mandatory for all cargo transported to and from offshore locations.

A risk assessment shall be conducted before a decision is taken not to secure cargo. The assessment and decision shall be recorded.

A copy of the UKOOA guidelines shall be made available onboard all supply vessels and Installations.

7.1 Cargo Carrying Units or Baskets

Before transfer on the Installation or to a supply vessel, the security of cargo inside Cargo Carrying Units (CCUs) or baskets etc shall be ensured. Additionally, the application of a tie-wrap (plastic cable tie) or similar method shall secure the doors of containers.

Prior to movement on the Installation or to a supply vessel, all units or equipment shall be checked to ensure:

- The security of panels
- The security of hatches
- That no loose equipment, tools or debris are lying on the roof, framework etc
- That all valves are closed to prevent spillage
- That there are no protrusions liable to cause snagging

Addendum 1 References

Regulations

- (1) Control of Substances Hazardous to Health Regulations 1999, SI 1999/No 437, ISBN 011 082087 8.
- (2) Freight Containers (Safety Convention) Regulations 1984, SI 1984/No 1890 ISBN 011 047890 8.
- (3) Health and Safety at Work etc Act (Chapter 37) 1974, ISBN 010 543774 3.
- (4) Lifting Operations and Lifting Equipment Regulations 1998, SI 1998/No 2307 ISBN 71 761532 4.
- (5) Manual Handling Operations Regulations 1992, SI 1992/No 2793, ISBN 011 025920 3.
- (6) Merchant Shipping (Carriage of Cargoes) Regulations 1997, SI 1997/No19, ISBN 011 064954 0 X (as amended by SI 1997/No 2366).
- (7) Merchant Shipping (Dangerous Goods and Marine Pollutants) Regulations 1997, SI 1997/No 2367, ISBN 011 064955 9.
- (8) Provision and Use of Work Equipment Regulations 1998, SI 1998/No 2306, ISBN 11 079599 7.
- (9) The Chemicals (Hazard Information and Packaging for Supply) Regulations 1994, SI 1994/No 3247, ISBN 011 043877 9 (as amended by SI 1999/No 3194).
- (10) The Chemicals (Hazard Information and Packaging for Supply) Regulations 1996, SI 1996/No 1092, ISBN 011 076037 9 (as amended by SI 1999/No 3194).
- (11) The Docks Regulations 1988, SI 1988/No 1655, ISBN 011 087655 5.
- (12) The Management of Health and Safety at Work Regulations 1999, SI 1999/No 3242, ISBN 011 0885625 2.
- (13) The Packaging of Explosives for Carriage Regulations 1991, SI 1991/No 2097, ISBN 11 015197 X.
- (14) Waste Management Regulations 1996, SI 1996/No 634, ISBN 11 054324 6.

Guidance

- (1) COSHH Essentials – Easy Steps to Control Chemicals 1999, HS(G)193, ISBN 071 762421 8.
- (2) Code of Practice for the Safe Use of Wire Rope Slings 1983, BS6210: 1983, ISBN 0 580 12502 5.
- (3) Dangerous Goods in Cargo Transport Units 1998, HS(G)78, ISBN 0 7176 1532 4.

- (4) Guidelines for the Safe Management and Operation of Offshore Support Vessels: UKOOA/Chamber of Shipping 2000, ISBN 190 300309 0.
- (5) Guide for the Stowage of Goods in Freight Containers 1982, BS5073: 1982, ISBN 0 580 12834 2.
- (6) International Maritime Dangerous Goods Code 2001.
- (7) Offshore Containers, Design, Construction, Testing, Inspection and Marking 1999, BSEN 12079: 1999, ISBN 0 580 326330.
- (8) Offshore Freight Containers Design and Certification – DNV Certification Notes 2.7-1: 1989.
- (9) Specification for Alloy Steel Shackles 1962, BS3551: 1962, ISBN 0 580 35090 8.
- (10) Standard Steel Wire Ropes – Specifications for General Requirements 1987, BS302: 1987, ISBN 0 580 15632 X.
- (11) Specification for Thimbles in Wire Ropes 1958, BS464: 1958 (work in hand), ISBN 0 580 00885 1.
- (12) Specification for Wire Rope Slings and Sling Legs for General Lifting Purposes 1983, BS1290: 1983, ISBN 0 580 12432 0.
- (13) British Standard Code of Practice for Safe Use of Cranes (Offshore) 1998, BS7121-11-98, ISBN 0 580 29503 6.
- (14) Guidelines on the Safe Packing and Handling of Cargo, UKOOA.

Internet Guidance

- (1) UK Statutory Instrument Website: <http://www.legislation.hmso.gov.uk/stat.htm>
- (2) British Standards Website: <http://www.bconline.techindex.co.uk>
- (3) Maritime and Coastguard Agency Website: <http://www.mcagency.org.uk>
- (4) Step Change Standard Lifting and Crane Operating Procedures Group:
http://www.oil-gas-safety.org.uk/taskb/lift_crane/lift_s.htm
- (5) Health and Safety Executive Home Page: <http://www.hse.gov.uk/hsehome.htm>
- (6) Chamber of Shipping: <http://www.british-shipping.org>
- (7) United Kingdom Offshore Operators Association: <http://www.oilandgas.org.uk>
- (8) Cross-industry Safety Alert Database SADIE:
 - <http://www.csid.steel-sci.org>
 - <http://www.oil-gas-safety.org.uk>

Addendum 2

Cargo Handling and Toolbox Talk Record Form

Date:		Record Form No:		Location:	
Crane/Equipment/Site Checks (visual)	Yes	No	Hazards (insert others in 10)	Yes	No
(1) Crane daily checks completed			(1) Noise		
(2) Cargo handling pennant			(2) Entrapment/positions of people		
(3) Shackles			(3) Fall from height		
(4) Lifting Hooks			(4) Overhead hazards		
(5) Tag/handlines			(5) Slip/trip hazards – eg uneven surface		
(6) Radio's integrity and communication checked			(6) Entanglement in tag/handlines		
(7) Permit(s) to Work in place (visible at job site as applicable)			(7) Entrapment		
(8) Laydown areas free from obstructions			(8) New/inexperienced personnel – competence		
(9) Cargo carrying units			(9) Moving Machinery		
			(10)		
Relevant Persons at Toolbox Talk			Protective Equipment		
(1) Foreman/Chargehand			(1) Eye Protection		
(2) Cargo Handlers/Deck Crew			(2) Gloves		
(3) Crane Operator			(3) Safety Boots		
(4) Banksman			(4) Hard Hat		
(5) Shift Supervisor			(5) Protective Coveralls		
(6) Forklift Truck Operator(s)			(6) High vis-vest/waistcoat		
			(7) Hearing protection		
			(8) Fall arrest protection		
Job Introduction, Plan, Methods			Lifting Operations		
(1) Discuss the task assigned/individual assignments			(1) Is a lifting plan required?		
(2) Discuss deck plan/manifest – any special instructions			(2) Appoint and identify the designated Banksman/Banksmen, ensure they are known to others		
(3) Identify potential hazards/obstructions/ conflicting activities			(3) Agree method of signalling with Banksman/ Crane Operator <ul style="list-style-type: none"> • Radio • Hand Signalling 		
(4) What other conflicting activities will be going on associated with the lifting operations?			(4) Advise if any heavy lifts – review Permit to Work conditions		
(5) Any dangerous goods lifts – identify precautions to be taken			(5) Discuss whether adequate experienced personnel for task – deploy additional if necessary		
(6) Discuss/review risk/JSA assessments/ lifting plan – attach to permit if applicable			(6) Consider erection of barriers/signs at job site		
(7) Advise what precautions/control measures/ PPE to be applied			(7) Discuss positioning of personnel and identification of escape routes		
			(8) Adverse weather policy		
Responsibilities			Stop the Job		
(1) Assign individual responsibilities for each stage of the task			(1) Personnel advised they have stop the job authority		
Confirm work party understanding of briefing and satisfaction that it is safe to commence task					
Deck Foreman/Charge hand	Signed		Print Name		Date
Cargo Handlers/Deck Crew	Signed		Print Name		Date
Crane Operator	Signed		Print Name		Date
Banksman	Signed		Print Name		Date
Services Supervisor	Signed		Print Name		Date

UKCSSOP043_024.doc

Addendum 3

General Instructions for Crane Operators

Do Nots

- (1) Do not operate the crane until you are certain that personnel descending from the crane or its structure are well clear/outwith the swing path of the crane superstructure and have signalled the all-clear to you.
- (2) Do not authorise access to the crane or its superstructure until the crane has been brought to a complete halt. Ensure that personnel accessing the crane advise of their intentions when onboard. Signs that state 'authorised personnel only beyond this point' shall be posted at a strategic point, eg at the entrance of the crane access point.
- (3) Do not lift loads outside or inside the working radius of the crane.
- (4) Do not depend on limits or cut-outs to stop the boom or load-line motions.
- (5) Do not engage slew parking brake or lock until the crane superstructure has come to a halt.
- (6) Do not use slewing motion to drag loads over the decks. This imposes severe side stresses on the crane boom.
- (7) Do not carry out single point lifts with one handling pennant hooked into the other. This presents snagging potential.
- (8) Do not, on cranes equipped with more than one hook block, operate the crane with a handling pennant or other ancillary equipment attached to the stowed hook block.
- (9) Do not lift long or awkward loads without taglines attached (except when backloading to supply vessels). If it is deemed necessary to use taglines during supply vessel backloading operations then a suitable and sufficient risk assessment shall be undertaken.
- (10) Do not use signals via a Banksman when lifting personnel. Always insist on being able to see them for yourself.
- (11) Do not continue with a lifting operation if you lose sight of or radio contact with your designated Banksman.
- (12) Do not lift loads from baskets or containers until all personnel have come out of the unit concerned.

- (13) Do not interfere with Rated Capacity Indicators (RCIs) or other safety equipment attached to the crane. This is illegal.
- (14) Do not allow personnel to ride on crane hook blocks or on loads.
- (15) Do not slew the crane outboard with a load on the hook when divers are working in the vicinity.
- (16) Do not leave the crane control cabin when there is a load suspended on the hook.
- (17) Do not use the crane if a fault or defect is liable to compromise the safety of personnel or lead to the possible damage of equipment.
- (18) Do not tamper with or adjust any equipment on the crane unless you have the technical qualification, are competent and/or are authorised to do so.
- (19) Do not operate the crane unless the gross overload protection system pressures are in safe operating range (where system fitted).
- (20) Do not over-grease crane components. This could lead to brake and clutch slippages during lifting operations.
- (21) Do not operate the crane in weather conditions outside the parameters laid down in the Installation's safe operating procedures or standing orders manual.
- (22) Do not lift loads of large surface areas, eg steel plates in high wind conditions. Always assess the effect the weather conditions could have on the behaviour of the load.
- (23) Do not carry out supply vessel discharging or backloading operations with the RCI adjusted to Installation duties. The appropriate seastate duties must be selected and/or cam fitted.
- (24) Do not carry out cargo transfer to/from diving vessels or attendant semisubmersibles unless the appropriate seastate duty has been selected.
- (25) Do not lift wire ropes, cables or other material/equipment of a similar nature that are not already spooled on drums provided for that purpose. An appropriate risk assessment must be conducted and one of the following methods adopted:
 - The material has been coiled and then slung securely using an approved slinging arrangement method involving at least a double wrap and bite
 - The material can be lifted in a single strand provided the lifting arrangement is secured approximately 1/4 to 1/3 from one end by use of a clamp or other device to prevent the lifting strop slipping
 - A certified lifting device specifically designed for the purpose is used

Dos

- (1) Do ensure that you are fully conversant with the relevant Installation safe operating procedures and Standing Instructions.
- (2) Do ensure that you are fully conversant with the controls and characteristics of the crane you are about to operate.
- (3) Do carry out a visual check of the crane to determine serviceability.
- (4) Do complete the manufacturer's or owner's pre-start and operational checklist prior to commencing crane operations.
- (5) Do report any defects to your line supervisor or to the individual designated by the Offshore Installation Manager (OIM) as the Responsible Person.
- (6) Do post 'do not operate' signs in a prominent position in the operator's cabin if the crane is out of use for maintenance etc.
- (7) Do ensure that the crane engine (or alternative powerpack) is isolated and that systems have been depressurised while maintenance is being carried out.
- (8) Do ensure that the RCI is fully operational and that the appropriate adjustments have been made to suit prevailing conditions, eg Installation/seastate duties, number of reeving falls on hook block.
- (9) Do confirm the security of the manually activated emergency load release controller to ensure that it cannot be inadvertently activated.
- (10) Do be aware of the wind speed and direction and, where applicable, seastate.
- (11) Do keep within the crane's operating radius at all times during lifting operations.
- (12) Do make use of the crane's boom safety pawl (if fitted) when lifting loads at long radii, heavy loads, when raising boom from its rest, from across the deck or when the crane is parked or under maintenance.
- (13) Do ensure that a cargo handling pennant, of sufficient length/capacity and sheathed in hi-vis cover, is used when discharging and/or backloading supply vessels.
- (14) Do ensure that only the required number of handling pennants for carrying out the lift are attached to the crane hook, ie single point lift – single pennant (this particularly applies when engaged in supply vessel operation).
- (15) Do ensure that you are aware of any obstruction and/or activities that are ongoing within the operating radius of the crane.
- (16) Do ensure that the Banksman has taken up position to determine the crane boom proximity to potential collision points when carrying out lifts from areas such as the drillfloor, flare tower base, radio mast etc.
- (17) Do talk to the Banksman to ensure that you are aware of all aspects/requirements of the lifting operation to be undertaken and of the signalling method to be used.
- (18) Do ensure that a Banksman is present when stowing the boom in its cradle.

- (19) Do function check all hoist and lower control systems prior to commencement of lifting operations. Particular care must be taken when operating friction clutch and brake-type cranes. Ensure the co-efficiency of these components as it is crucial that they are maintained in a clean and dry condition.
- (20) Do operate the crane controls as smoothly as conditions allow and try to avoid 'snatch' as shockloading imposes undue strain on the crane, its equipment and support structure.
- (21) Do exercise extreme caution when using friction clutch and brake-type cranes to lower heavy loads. At all times ensure that the load's speed of descent is retained under control and within the capabilities of the crane's load lowering, transmission and braking system.
- (22) Do exercise caution when lowering the crane hook block such that the rope 'payout rate' is not exceeded, thus preventing possible damage to the rope.
- (23) Do everything possible to operate and maintain the crane in a manner that ensures the complete safety of the crane, the Installation and all personnel in the vicinity.
- (24) Do talk to the Crane Operator from the previous shift before he/she leaves the crane to determine if the crane has any defects that require immediate rectification or if there is any other important information that shall be known. Similarly, at the end of each tour of duty ensure that safety critical information is relayed to relief personnel.
- (25) Do ensure that loads are landed safely and the crane is secured if an Installation emergency occurs.
- (26) Do ensure that you are familiar with the operation of emergency load release and load lowering equipment (if fitted).
- (27) Do ensure that during activities outwith the crane cab, your portable radio is secured to your person in a protective pouch/holster by means of a waistbelt or shoulder lanyard.
- (28) Do ensure that during crane maintenance activities tools, equipment and lubricants are retained in a secure manner. This is particularly important when working at heights. Where hand tools are being used in these circumstances the use of a 'tool saver' device is mandatory.
- (29) During winter weather conditions a buildup of snow and ice on the crane boom is possible. When these conditions prevail, crane operational personnel shall inspect the crane boom and take necessary actions to ensure the hazard potential is alleviated.

Addendum 4

Use of Lifting Accessories

Paragraph		Page
1	Introduction	1
2	Principles of Tension	1
3	Sling Angles	3
4	Mode Factor (M)	4
5	Corrosion	4
 Figure		
1	Tension (T)	2
2	Tension	2
3	Sling Angles	3
4	Sling Capacity Variation	4

1 Introduction

The way lifting gear is used, and the conditions under which it is used, can often indicate special areas of attention for the examiner.

This is especially true for gear used offshore, and in particular for that used in the transfer of loads between ship and rig/Installation.

Anyone using lifting gear must understand the effects of angles in lifting suspended loads. The principles of tension are very important. Simply, if a suspended load is hanging vertically, with no other movement, then the tension in the supporting gear is equal to the weight of the load.

If the angle of the suspension is not 0 (or vertical), then the tension in the suspension must increase.

There are now two forces acting on the load. One is vertical (gravity) and one is horizontal.

When more than one sling is used on the load, there is usually an angle between the legs, and this means that the tension in each sling is **more** than the weight of its proportion of the load. (This would be half for an equally slung uniform load.)

Transit slings are only to be used for offloading and backloading drilling tubulars, ie casing, conductor etc, and scaffolding tubes.

Transit slings are **not** to be used for general platform lifting.

Once a transit sling has been removed from its load it must be inspected and placed in the designated storage area.

All transit slings must comply with the Colour Coding Procedure for Portable, Fixed and Circulating Lifting Equipment (UKCS-TI-013) for colour coding.

2 Principles of Tension

The tension in equally loaded slings is easily demonstrated using the following formula:

$$\frac{W \times L}{No \times H} \text{ Tension (in each sling)}$$

W = Weight of load

L = Length of slings

No = Number of slings

H = Height (vertical distance between attachment points)

It can be seen that tension will increase as the angle between the sling legs increases. Refer to Figures 1 and 2.

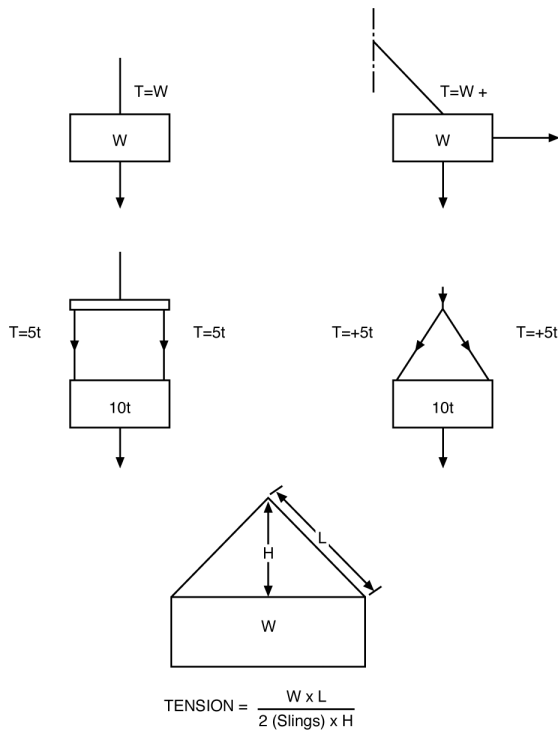

UKCSSOP043_008.ai

Figure 1 Tension (T)

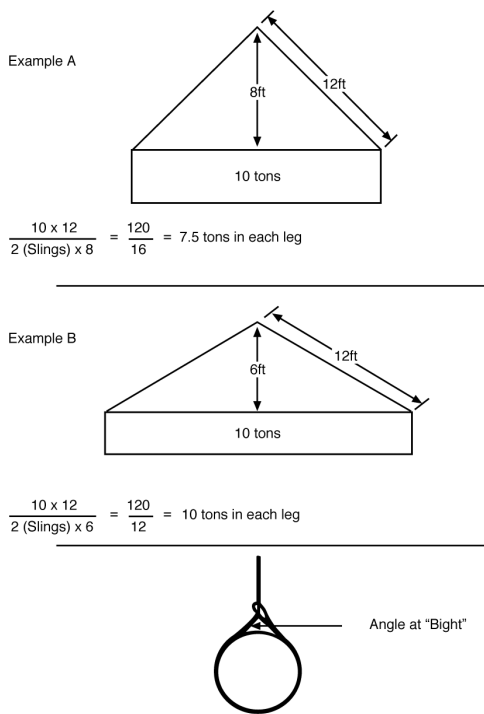

UKCSSOP043_009.ai

Figure 2 Tension

3 Sling Angles

When lifting with multi-leg slings, these are rated at a certain tonnage from 0° to 90°. This Safe Working Load (SWL) shall not be exceeded even if the angle is less than 90°. When using single slings in pairs however, always be aware of the increased loadings in the slings when lifting at an angle.

For the above reason, the SWL of a pair of single slings decreases as the angle between them increases.

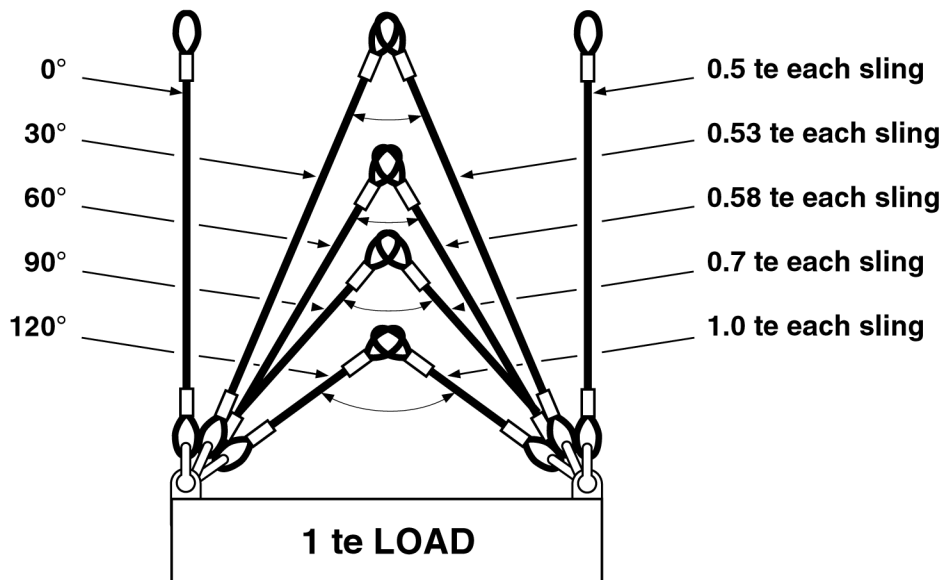

eg	At	0°	-	SWL	=	SWL of one sling x 2
		30°	-	SWL	=	SWL of one sling x 2 x 0.966
		60°	-	SWL	=	SWL of one sling x 2 x 0.866
		90°	-	SWL	=	SWL of one sling x 2 x 0.707
		120°	-	SWL	=	SWL of one sling x 2 x 0.5
OR						
	At	0°	-	SWL	=	SWL of one sling x 2
		30°	-	SWL	=	SWL of one sling x 1.93
		60°	-	SWL	=	SWL of one sling x 1.73
		90°	-	SWL	=	SWL of one sling x 1.414
		120°	-	SWL	=	SWL of one sling only

UKCSOP043_010.ai

Figure 3 Sling Angles

4 Mode Factor (M)

Always consider the variation in sling capacity when slinging in various configurations.

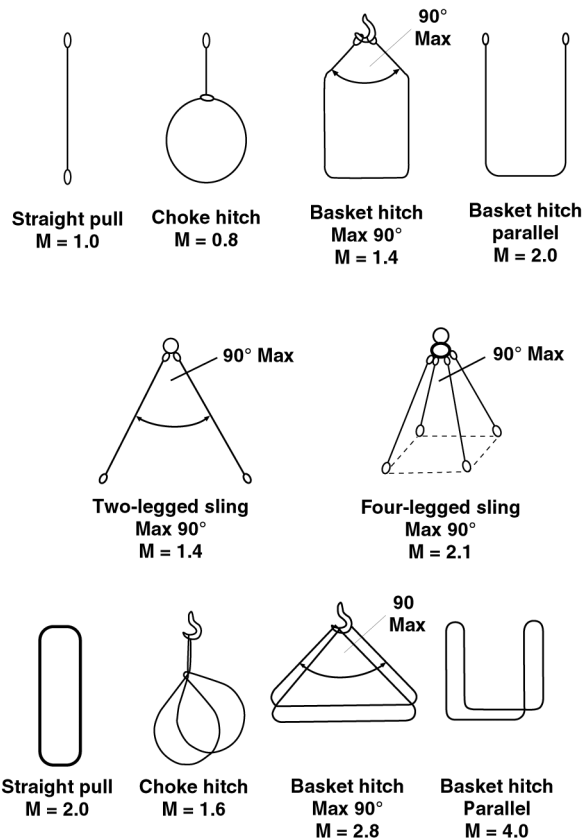

UKCSOP043_011.ai

Figure 4 Sling Capacity Variation

Multiply the SWL of one leg by the mode factor (M) to obtain the SWL of the configuration. (The last four modes/ratings do not apply to 'round' slings – refer to Addendum 7 Figure 2).

If slings are used with a 'choke' or 'reeving' hitch, then there is another angle to consider – the angle at the 'bight'.

5 Corrosion

Corrosion is a problem with lifting gear in general, and with offshore equipment in particular.

Exposure to seawater is an obvious reason, but there are also chemicals used during drilling and production operations that can seriously affect the materials used in lifting gear manufacture.

Addendum 5 Eyebolts

Paragraph		Page
1	Introduction	1
2	Safe Use of Eyebolts	1
3	Procedure for Using Eyebolts	2
Figure		
1	Types of Eyebolt	1

1 Introduction

Eyebolts are used for lifting loads that may be heavy and concentrated, and are used for general lifting and for permanent attachment to loads that need to be moved occasionally.

2 Safe Use of Eyebolts

The two types of eyebolts in common use are shown in Figure 1. The use of the wrong type of eyebolt is not an uncommon contributory cause of accidents.

Dynamo eyebolts shall not be used for lifting.

It is dangerous to use a hook that jams in an eyebolt as, under load, serious weakening of both eyebolt and hook could occur leading to failure at some later date due to the incipient damage started at the time of the jam. If the hook available is too large for the eyebolt concerned, a shackle of adequate size shall be fitted to the eyebolt to accommodate the hook.

Where inclined to load conditions are encountered, for example when a multi-legged sling is used, collar eyebolts or eyebolts with links must be used. The collar eyebolt that used to be referred to as the service eyebolt, has a squat eye that is too small to accommodate a hook, and so a shackle is always necessary.

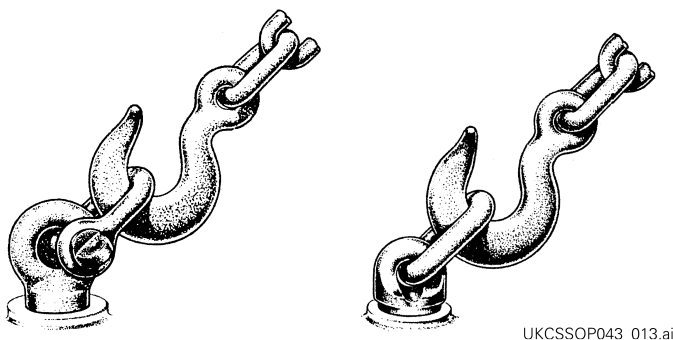

Figure 1 Types of Eyebolt

Collar eyebolts are intended for permanent attachment to heavy pieces of equipment and are usually fitted in pairs for use with shackles and two-legged slings. When two pairs of eyebolts are fitted to a single load then two, two-legged slings and a spreader bar shall be used in lifting.

The third type of eyebolt, the eyebolt with link, is intended for general lifting. Although its rated load decreases as the angle of the load to the axis of the screw thread increases, by virtue of its special construction these rated loadings are greater than those of a collar eyebolt of equivalent vertical Safe Working Load (SWL).

The collar, which plays an important part in the strength of the screw shank, shall be machined smooth and flat, and care shall be taken to ensure that the mating surface is smooth, flat and at right angles to the axis of the tapped hole.

The hole shall be of sufficient depth to accept the full length of the eyebolt shank and to allow the eyebolt to be pulled down tight. The plane of the eye shall be in line with the direction of the pull, but where this is not possible, a washer or horseshoe-shaped shim may be used to alter the position to the required direction and still allow the eyebolt to be fully tightened against the mating surface. The use of shims or washers shall be avoided if possible, but if they are used they shall be of the least possible thickness and no more than one shall be used.

The thickness shall never exceed half the pitch of the thread on the shank of the eyebolt and the diameter shall not exceed that of the collar under which it is placed. The open part of a horseshoe shim shall in all cases point away from the direction of an inclined pull so that when the pull is taken the collar will always bed against solid metal.

3 Procedure for Using Eyebolts

- **Never** use home-made eyebolts
- Check the thread in a standard tapped hole. Fit is most important
- Check the SWL of the eyebolt before use
- The shoulder or collar of the eyebolt shall be flat, free from damage and at right angles to the threaded portion
- Examine the eyebolts for cracks, dents and corrosion pits before use
- Check the eye for wear. If 1/10th or more of the original diameter is worn, replace it
- Always ensure that eyebolts are screwed down tightly
- Eyebolts without collars are substantially weaker than those with collars and are unsuitable for inclined loading
- Remember that inclined loading substantially reduces the eyebolt's SWL
- When using eyebolts, do not thread a sling through the eye of the eyebolt. Use a pair of shackles

Addendum 6

Estimation of Weight

Paragraph	Page
1 Introduction	1
2 Weight Calculation	1
3 Weights of Various Materials	1
3.1 Metric Conversion	1
3.2 Estimation of Weight	1
3.3 Drillpipe	2
3.4 Drillcollars	3
3.5 Drill Casing	3
3.6 Conductor	3
3.7 Steel Plate: Average Weight	3
3.8 Pipes	4
3.9 Rolled Steel Joists: Average Weight	4
3.10 Round Steel Bars	4
 Figure	
1 Estimation of Weight (1)	5
2 Estimation of Weight (2)	6

1 Introduction

The most important step that a Slinger must take with any lifting operation is firstly to find out the weight of the load. If this essential information cannot be obtained, the Slinger must be able to calculate the weight using his own judgement and by using the tables or data contained in this manual.

2 Weight Calculation

Calculate the weight of the object taking into account:

- (1) The dimension of the object.
- (2) The material that the object is made of (steel, wood, concrete etc).
- (3) Any lifting points attached to the object, ie lifting lugs, eyebolts or any special sling attachment points.

Most lifting points welded to a piece of equipment will be made to accept a shackle. The lifting point will have a machined hole to accept a shackle pin, with a nominal clearance. The size or SWL marked on the shackle would be of help to the Slinger.

- Add 25% to the estimated weight. This will account for any errors of judgement
- Now select the lifting gear for the overall estimated weight that is your estimated weight plus 25%, and sling the load correctly

The time taken to calculate the approximate weight of any object is time well spent, and may avoid a serious accident through failure of lifting gear.

3 Weights of Various Materials

3.1 Metric Conversion

- To convert kilograms to (long) tons – multiply by 0.00098
- To convert tons to kilograms – multiply by 1016.05
- To convert feet to metres – multiply by 0.3048
- To convert kilograms to tons – multiply by 0.001
- To convert metres to feet – multiply by 3.281

3.2 Estimation of Weight

Estimate, then add 25%.

- 2240 lbs = 1 ton (long)
- 2000 lbs = 1 ton (short)
- 20cwts = 1 ton (long)
- 1000kg = 1 tonne (metric)

Average Weight		
	lbs/ft ³	kgs/m ³
Steel	490	7850
Lead	712	11,405
Cast iron	450	7208
Fresh water	62	993
Wet sand	120	1922
Reinforced concrete	150	2403
Loose cement	90	1442

3.3 Drillpipe

Average Weight	
Inches	lbs/ft
<i>Standard</i>	
2 7/8	10.4
3 1/2	13.3
5	19.5
5 1/2	21.9
5 7/8	26.4
<i>Heavyweight</i>	
6 5/8	61.8

Note: Weights for drilling items are typical, but will vary according to wall thickness. If there is any uncertainty concerning the actual weight, consult the Senior Toolpusher or BP Representative.

3.4 Drillcollars

Average Weight	
Inches	lbs/ft
4 3/4	47
6 1/2	100
7 3/4	3360 – 4600 per 30ft length
8	160
9 1/2	230
<i>Subs</i>	
86 lbs per ft length average (usually in lifting baskets maximum 5 ton)	

3.5 Drill Casing

Diameter	Number in Lift	Approximate Weight
5in	7	3 tons
7in	5	4 tons
9 5/8in	3	3.5 tons
13 3/8in	3	4 tons
18 5/8in	3	5 tons

3.6 Conductor

Diameter	lbs/ft
36in	550
30in	310
24in	304

3.7 Steel Plate: Average Weight

lbs per ft²	kgs per m²
1/4in thick 10	6mm thick 47.1
3/8in thick 15	10mm thick 78.5
1/2in thick 20	12mm thick 94.2
3/4in thick 30	20mm thick 157
1in thick 40	25mm thick 196

3.8 Pipes

Weight in lbs per ft Length	
Steel	Cast Iron
1in bore 2	4in bore 16
2in bore 5	5in bore 22
3in bore 8	6in bore 30
4in bore 10	9in bore 52

3.9 Rolled Steel Joists: Average Weight

Per Metre in kgs	Per ft in lbs
76mm x 76mm = 12.75	3 x 3 = 5 1/2
102mm x 44mm = 7.5	6 x 3 = 12
102mm x 102mm = 23	8 x 4 = 18
127mm x 76mm = 16.5	8 x 6 = 35
127mm x 114mm = 26.8	9 x 4 = 21
152mm x 127mm = 37.3	9 x 7 = 50
203mm x 152mm = 52.25	10 x 5 = 30
254mm x 114mm = 37	10 x 8 = 55
254mm x 203mm = 82	12 x 6 = 44
	14 x 6 = 57
	15 x 6 = 59
	18 x 7 = 75
	24 x 7 1/2 = 100

3.10 Round Steel Bars

lbs per ft Length		kgs per Metre Length	
Diameter	Weight	Diameter	Weight
10	0.6	1/2in	2/3
20	2.5	1in	3
25	3.8	1 1/2in	6
50	15.4	2in	11
100	61.6	3in	24
		4in	43

ESTIMATION OF WEIGHT

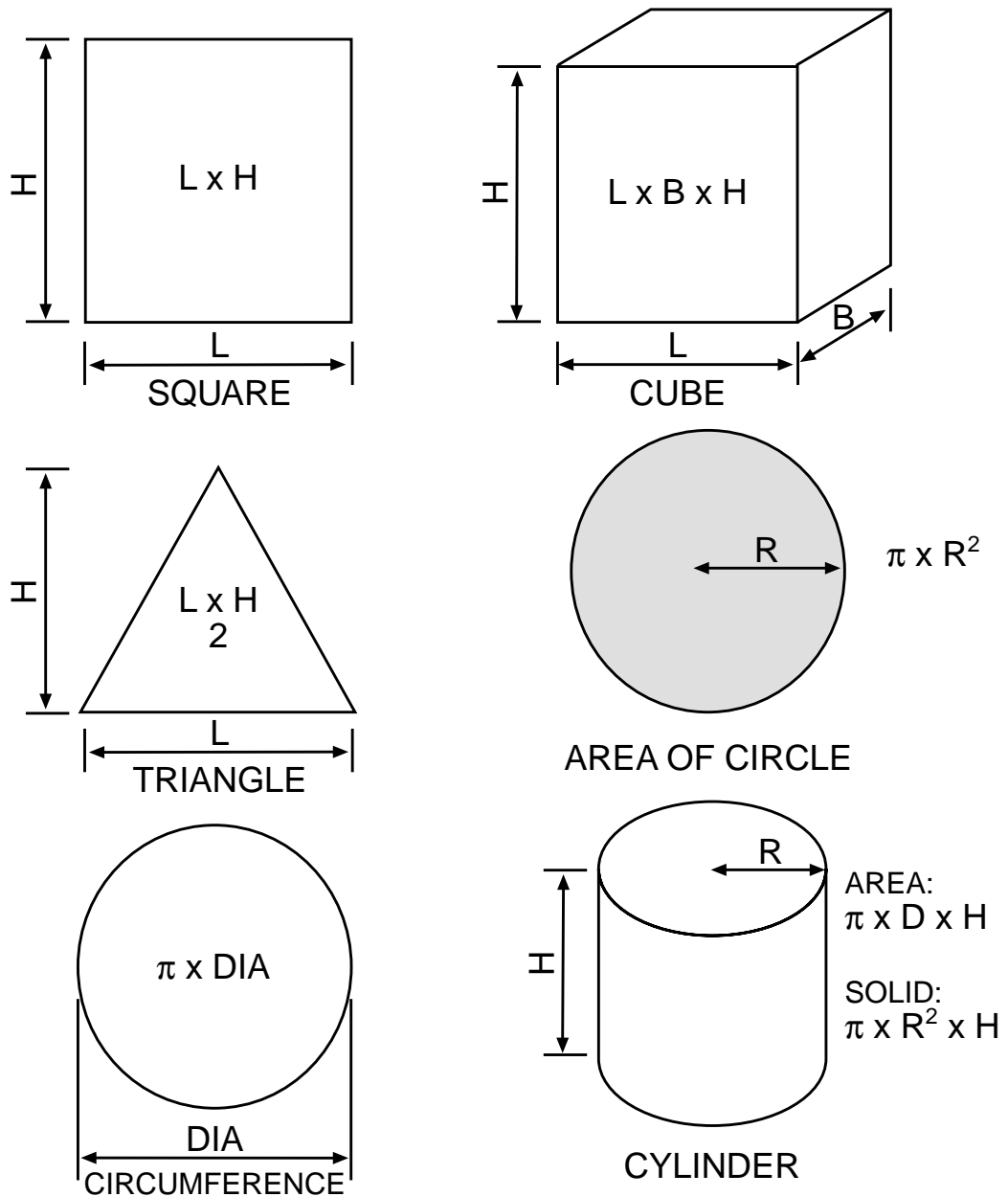

VALUE OF $\pi = 3.142$ OR $3 \frac{1}{7}$ OR $\frac{22}{7}$

IF 3 IS USED ADD 5% TO ESTIMATE TO CORRECT ERROR

REMEMBER: TO THE ESTIMATE ADD 25%

UKCSOP043_014.ai

Figure 1 Estimation of Weight (1)

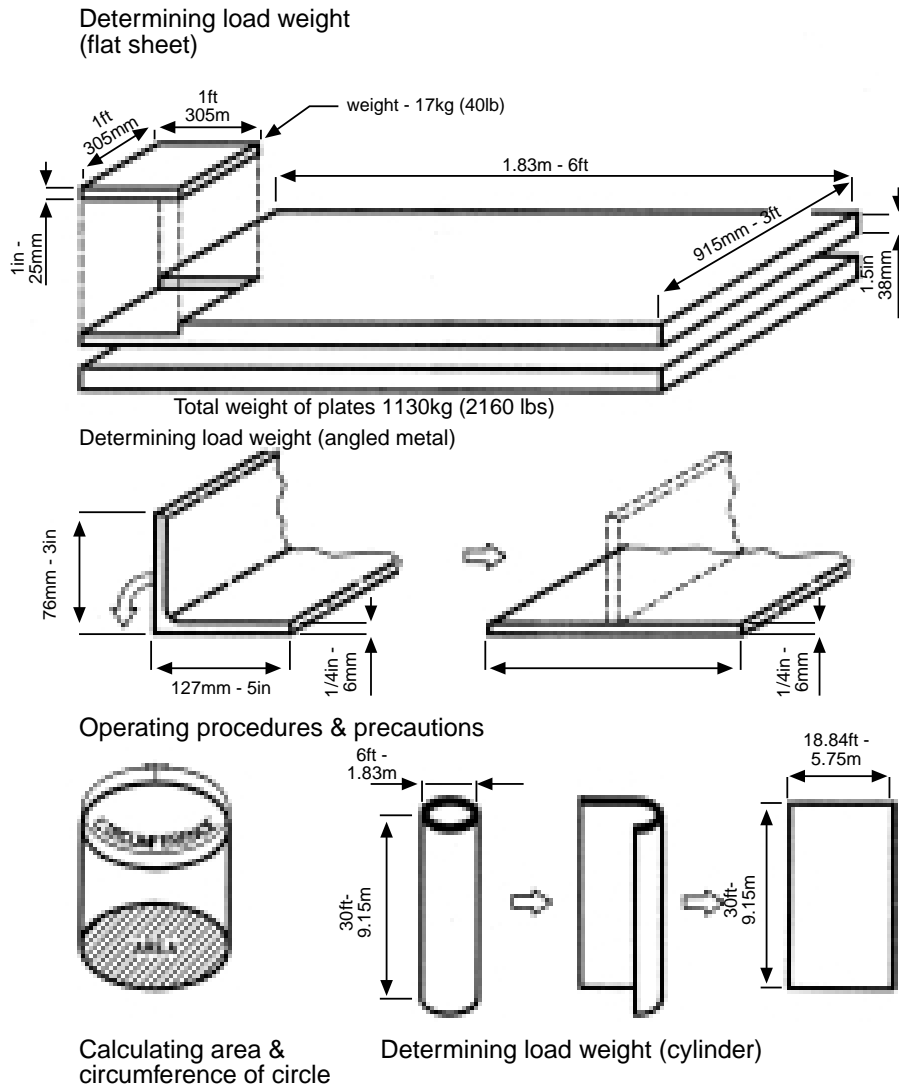

UKCSSOP043_015.ai

Figure 2 Estimation of Weight (2)

Addendum 7

Safe Working Loads and Breaking Loads

Figure		Page
1	Safe Working Loads of Wire Rope Slings	1
2	Safe Working Loads of Man-made Fibre Slings	2
3	Safe Working Loads of Alloy Grade 80 Chain Slings	3
4	Safe Working Loads of Alloy Shackles (US Federal Specification)	4
5	Safe Working Loads of Eyebolts	5
6	Safe Working Loads of Pairs of Eyebolts	6
7	Safe Working Loads of Turnbuckles/Rigging Screws	7



6 x 19 6 x 36 GROUPS STEEL CORE				6 x 19 6 x 36 GROUPS FIBRE CORE			
SAFE WORKING LOAD				SAFE WORKING LOAD			
Rope Dia	Single Leg	Leg Angle 0 to 90°		Rope Dia	Single Leg	Leg Angle 0 to 90°	
		2 leg	3 and 4 leg			2 leg	3 and 4 leg
mm	tonne	tonne	tonne	mm	tonne	tonne	tonne
10	1.3	1.8	2.7	10	1.2	1.7	2.5
11	1.6	2.1	3.3	11	1.4	2.0	3.0
12	1.8	2.6	3.9	12	1.7	2.4	3.6
13	2.2	3.0	4.5	13	2.0	2.8	4.2
14	2.5	3.5	5.3	14	2.3	3.2	4.9
16	3.3	4.6	6.9	16	3.0	4.3	6.4
18	4.2	5.8	8.7	18	3.9	5.4	8.1
19	4.6	6.5	9.7	19	4.3	6.0	9.0
20	5.1	7.2	10.8	20	4.8	6.7	10.0
22	6.2	8.7	13.1	22	5.8	8.1	12.1
24	7.4	10.4	15.5	24	6.9	9.6	14.4
26	8.7	12.2	18.2	26	8.1	11.3	16.9
28	10.1	14.1	21.2	28	9.3	13.1	19.6
32	13.1	18.4	27.6	32	12.2	17.1	25.6
35	15.7	22.0	33.1	35	14.6	20.4	30.7
36	16.7	23.3	35.0	36	15.4	21.6	32.4
38	18.6	26.0	39.0	38	17.2	24.1	36.1
40	20.6	28.8	43.3	40	19.1	26.7	40.0
44	24.8	34.7	52.1				
48	29.6	41.4	62.2				
52	34.8	48.7	73.1				
54	37.4	52.4	78.5				
56	40.2	56.3	84.4				
60	46.2	64.7	97.0				
64	52.4	73.4	110.0				
70	62.8	87.9	132.0				
76	74.0	103.6	155.0				

Note: These tables have been compiled in compliance with BS1290 1983 and BS302 Part 2 198. Uniform load method calculation used throughout.

UKCSSOP043_017.ai

Figure 1 Safe Working Loads of Wire Rope Slings

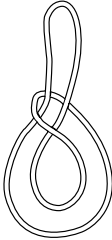
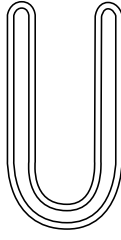
Round Slings:

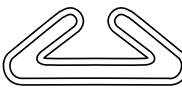
CAPACITIES				
				
Vertical	Choker	Basket	Basket 90°	Basket 120°
1.0t	800kg	2.0t	1.4t	1.0t
1.5t	1.2t	3.0t	2.1t	1.5t
2.0t	1.6t	4.0t	2.8t	2.0t
3.0t	2.4t	6.0t	4.2t	3.0t
4.0t	3.2t	8.0t	5.6t	4.0t
6.0t	4.8t	12.0t	8.4t	6.0t
8.0t	6.4t	16.0t	11.2t	8.0t
12.0t	9.6t	24.0t	16.8t	12.0t

Simplex (Single Ply) Web Slings:

Width mm	CAPACITIES				
	Vertical	Choke	Basket	Basket 90°	Basket 120°
50	1.0t	800kg	2.0t	1.4t	1.0t
75	1.5t	1.2t	3.0t	2.1t	1.5t
100	2.0t	1.6t	4.0t	2.8t	2.0t
150	3.0t	2.4t	6.0t	4.2t	3.0t
200	4.0t	3.2t	8.0t	5.6t	4.0t
250	5.0t	4.0t	10.0t	7.0t	5.0t
300	6.0t	4.8t	12.0t	8.4t	6.0t

Note: For duplex (2 ply) and endless web slings, double the above values.

UKCSSOP043_018.ai

The use of simplex slings automatically results in the category of lift being 'complicated'. Appropriate risk assessments and an approved lifting plan is required for their use.

Figure 2 Safe Working Loads of Man-made Fibre Slings

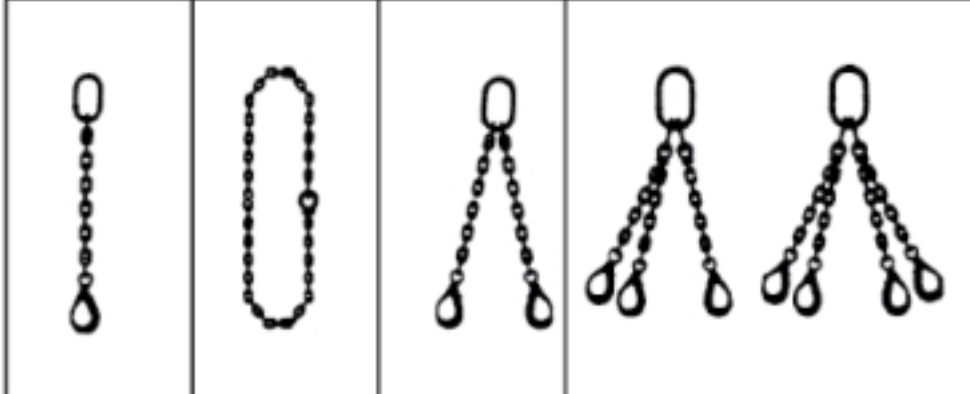

DIA	1 LEG	ENDLESS	2 LEG	3 and 4 LEG
7	1.5t	2.25t	2.1t	3.1t
8	2.0t	3.0t	2.8t	4.2t
10	3.2t	4.8t	4.5t	6.7t
13	5.4t	8.1t	7.6t	11.4t
16	8.0t	12.0t	11.3t	16.9t
19	11.5t	17.2t	16.2t	24.3t
22	15.5t	23.25t	21.9t	32.8t
23	16.9t	25.3t	23.8t	35.3t
26	21.6t	32.4t	31.0t	46.0t
32	32.0t	48.0t	45.0t	68.0t
	RATED AT 0°		RATED AT 90°	

Note: The above load working limits apply only to normal conditions of use in straight configuration and equally loaded legs.

UKCSSOP043_019.ai

Figure 3 Safe Working Loads of Alloy Grade 80 Chain Slings

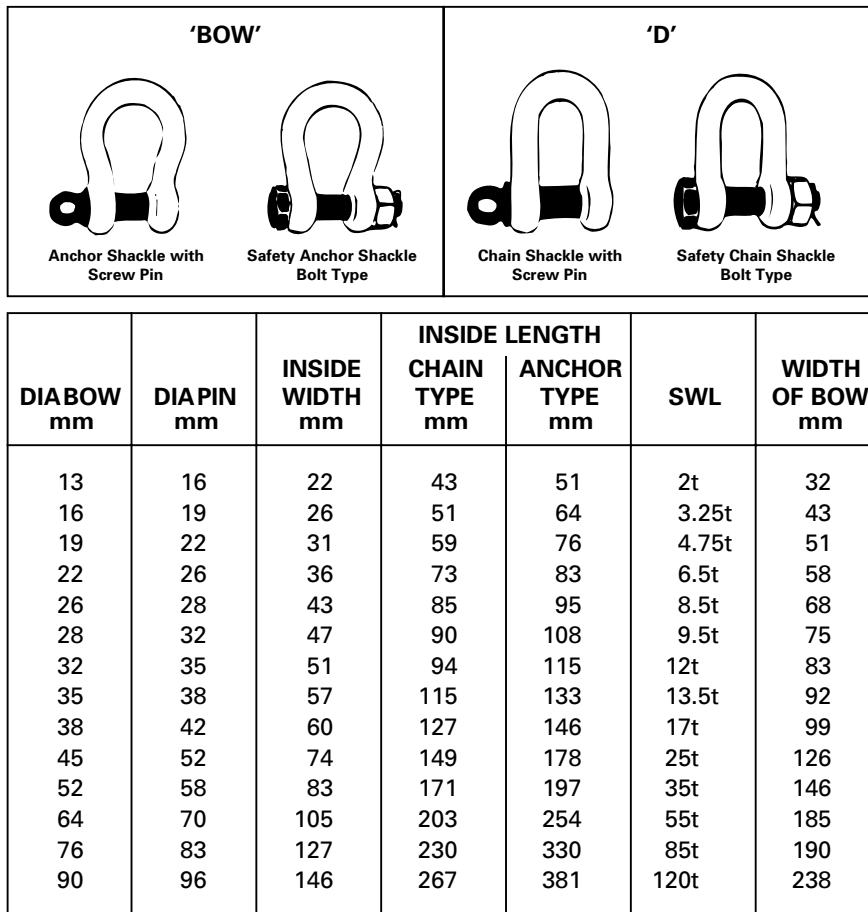

Note: Minimum breaking strength = 6 x SWL.
(Proof-loaded to ILO tables).

UKCSSOP043_020.ai

Figure 4 Safe Working Loads of Alloy Shackles (US Federal Specification)

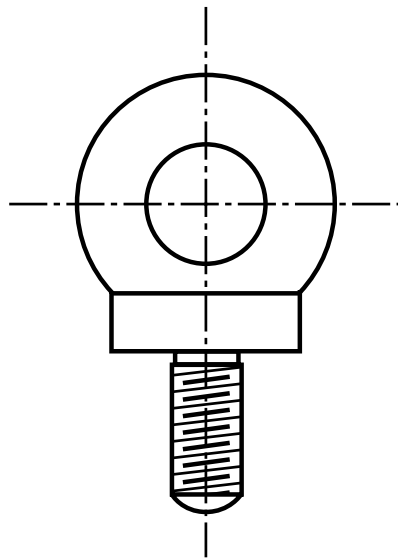

COLLAR EYEBOLTS TO BS4278 TABLE 1		
NOMINAL DIA mm	SWL (VERTICAL) 1968 PATTERN	SWL (VERTICAL) 1984 PATTERN
12	320kg	400kg
16	630kg	800kg
18	1.0t	-
20	1.25t	1.6t
22	1.6t	-
24	2.0t	2.5t
27	2.5t	-
30	3.2t	4.0t
33	4.0t	-
36	5.0t	6.3t
39	6.3t	-
42	-	8.0t
45	8.0t	-
48	-	10.0t
52	10.0t	12.5t
56	12.5t	16.0t
64	16.0t	20.0t
70	20.0t	-
72	-	25.0t
76	25.0t	-

UKCSSOP043_021.ai

Figure 5 Safe Working Loads of Eyebolts

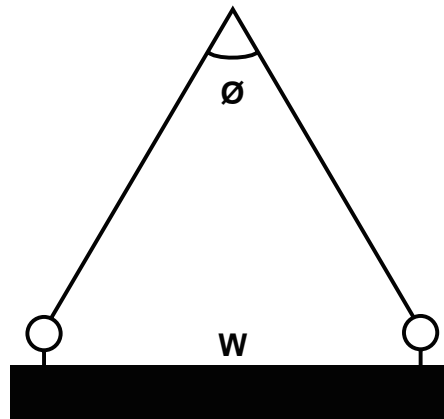

Maximum load W to be lifted by a pair of eyebolts when the angle between the sling legs is Ø

SAFE WORKING LOADS OF PAIRS OF EYEBOLTS				
SINGLE VERTICAL	PAIR VERTICAL	0°<Ø<30°	30°<Ø<60°	60°<Ø<90°
1.0t	2.0t	1.3t	800kg	500kg
1.25t	2.5t	1.6t	1.0t	630kg
1.6t	3.2t	2.0t	1.25t	800kg
2.0t	4.0t	2.5t	1.6t	1.0t
2.5t	5.0t	3.2t	2.0t	1.25t
3.2t	6.4t	4.0t	2.5t	1.6t
4.0t	8.0t	5.0t	3.2t	2.0t
5.0t	10.0t	6.3t	4.0t	2.5t
6.3t	12.6t	8.0t	5.0t	3.2t
8.0t	16.0t	10.0t	6.3t	4.0t
10.0t	20.0t	12.5t	8.0t	5.0t
12.5t	25.0t	16.0t	10.0t	6.3t
16.0t	32.0t	20.0t	12.5t	8.0t
20.0t	40.0t	25.0t	16.0t	10.0t
25.0t	50.0t	32.0t	20.0t	12.5t
REDUCTION FACTOR		0.63	0.4	0.25

UKCSSOP043_022.ai

Figure 6 Safe Working Loads of Pairs of Eyebolts

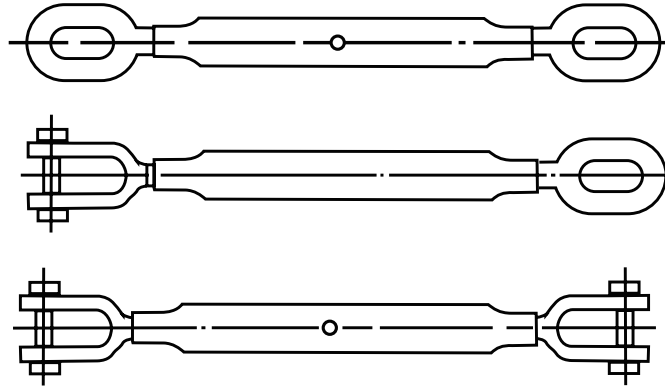

BS4429	
DIA (mm)	SWL
10	300kg
12	500kg
16	750kg
20	1.25t
22	2t
27	3t
30	4t
33	5t
39	6t
42	7.5t
48	10t
56	15t
64	20t
72	25t
76	30t
85	40t
100	50t

US FED SPEC	
DIA (ins)	WLL
3/8	545kg
1/2	1.00t
5/8	1.59t
3/4	2.36t
7/8	3.27t
1	4.55t
1 1/4	6.90t
1 1/2	9.73t
1 3/4	12.73t
2	16.82t
2 1/2	27.27t
2 3/4	34.09t

Note: These tables do not apply to units fitted with hooks. Refer to the manufacturer's literature.

UKCSSOP043_023.ai

Figure 7 Safe Working Loads of Turnbuckles/Rigging Screws